

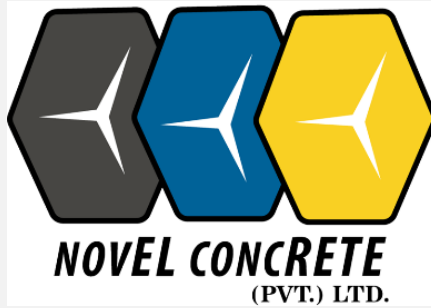

NOVEL CONCRETE
(PVT) LTD.





Suit # 306, 3rd Floor Century Tower, Kalma Chowk, Main Boulevard, Gulberg, Lahore
Tel: +92-42-35913913

INTRODUCTION

Novel Concrete leads the precast and interlocking concrete manufacturers in Pakistan. The company is known for its distinguished and reputed image set by satisfactory service delivery for more than 15 years now. We provide top quality products satisfying national and international specifications; the quality is achieved through the best research and state-of-the-art technology.

Novel Concrete delivers a wide range of precast concrete products including pavers, slab and wall panels, paving stones and blocks, kerbstones and barriers, EPS panels, and pre-stressed structural elements. Produced in automated and controlled indoors, the products manufactured are lighter, aesthetically pleasing, economical, sustainable, energy and eco-efficient. Our pavers boast high durability, un-questioned reliability and can resist various traffic and severe weather conditions. They can survive high inflows of heavy traffic, fierce abrasion of walkways and sustained pedestrian traffic on the one hand and heaviest compressive loads of machinery and material handling equipment at Port traffic on the other. Capable of bearing furious environmental and mechanical loads, these pavers find applications in countless facilities including petrol pumps, service stations, numerous residential driveways, pedestrian footpaths, commercial and industrial parking areas, recreational and monumental spots.

Precast roofing and wall systems that we provide address the demands of modern civil engineering applications such as lightweight construction, reduced structural loads, quick installation, improved thermal and acoustic performance, and the need for greener and sustainable development. We as a manufacturer take both the social and environmental responsibilities while producing and managing our deliverables.

Our products are approved by all the local government and semi-government departments as well as many testing laboratories confirming them appropriate for various applications. **Novel Concrete** enjoys a long list of satisfied and reputed clients and guarantee exemplary references.

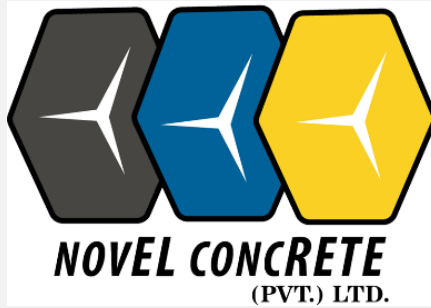

Suit # 306, 3rd Floor Century Tower, Kalma Chowk, Main Boulevard Gulberg, Lahore
Tel: +92-42-35913913

MISSION STATEMENT

Our mission is to generate a cluster of satisfied customers Pakistan-wide through continuously improving the design, performance, durability, longevity, and sustainability of our products and services. Novel Concrete commits itself to an innovative spirit and excellence service. Our company is defined by upright ethics and core values which include:

1. Client Focus

At Novel Concrete, client focus is our utmost priority. We carefully consider the requirements of our customers and endeavour to understand their needs. We get into the dearest perspective of our client's and strive to provide best solutions against their requirements. We aspire to create long-term and effective relationships with our customers and create a synergistic environment at business.

2. Research Driven

Research is what sets us apart. We aim at bringing novel engineering materials to the construction industry of Pakistan. Our research funding and collaboration with academia have produced ground-breaking researches and innovation making us stay ahead of our competitors. In the past, we have designed, developed, and tested advanced engineering materials such as Engineered Cementitious Composites (ECC), Geopolymer Composites and Green Concrete (GC). Moreover, we have conducted research to sustainably manufacture concrete using industrial by products such as Fly ash and Slag.

3. Uncompromising Quality

We bear zero tolerance against quality. It is part of our ethics to operate at the highest quality standards and we pursue to be honest and fair with our clients.

4. Sustainability

We believe that it is our responsibility to take care of our environment. For this reason, we aim to extract our raw materials locally from sustainable resources. This not only protects the environment but also brings economic benefits to local community.

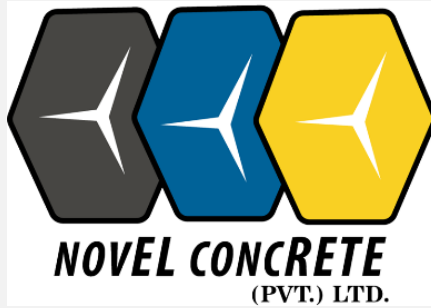

Suit # 306, 3rd Floor Century Tower, Kalma Chowk, Main Boulevard, Gulberg, Lahore
Tel: +92-42-35913913

DIRECTOR'S MESSAGE



We started with a vision to provide innovative and sustainable construction materials, and with consistent, untiring, and sincere efforts we have established an organization to serve construction industry; we are still improving day-by-day. Over 15 year's devotional efforts we have achieved a well-known and distinguished position in precast and interlocking concrete manufacturing industry and will continue to strive hard with enhanced far-sightedness for innovation.

In today's ever increasing competitive global market, we have realized that one of the successful strategies for sustainability in construction is to introduce research and innovation based production that would fulfil the market needs. Aligned with this strategy, we have extended our visualization and decided to establish a top-notch engineering organization in Pakistan that would produce consistent quality products at affordable cost for everyone.

We are working at our dreams and our efforts have put us on the track to lead precast manufacturers in Pakistan.

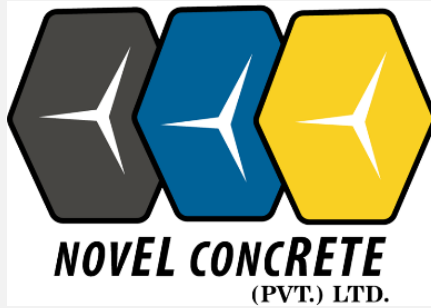

Suit # 306, 3rd Floor Century Tower, Kalma Chowk, Main Boulevard, Gulberg, Lahore
Tel: +92-42-35913913

OUR TEAM



ABID HUSSAIN
CEO



Ch. SAJID MAHAIS
DIRECTOR



FAMIR LATIF
GM SALES & MARKETING
Graduation,
Procurement Management



SHER ZAMAN
SALES MANAGER
Master's in Statistics,
Specialization in Survey & Estimation



MUNIB UL REHMAN
TECHNICAL MANAGER
BSc in Civil Engineering
MSc in Integrated Building Design



AWAIS ASLAM
SITE ENGINEER
BSc in Civil Engineering

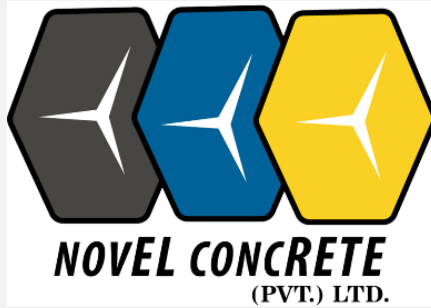

Suit # 306, 3rd Floor Century Tower, Kalma Chowk, Main Boulevard Gulberg, Lahore
 Tel: +92-42-35913913

OUR PRODUCTS

TUFF TILES

- High Strength
- Skid resistant
- Better interlocking
- Durable and reusable
- High plant controlled quality
- Green product



Available Sizes		
50mm	60mm	80mm

Available Strength: 4000 Psi, 7000 Psi, 8000 Psi

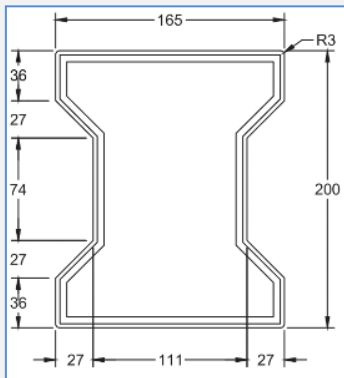

Hi-Lock

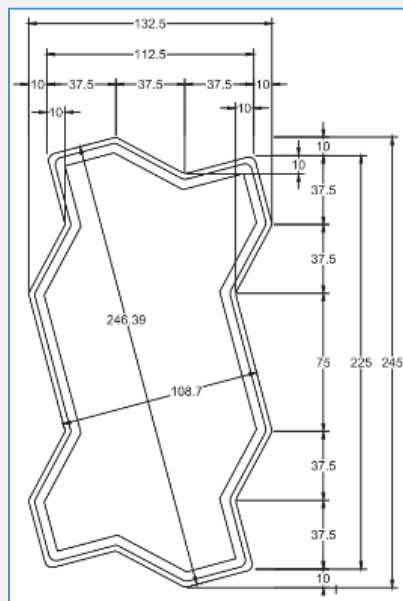

Uni-Block

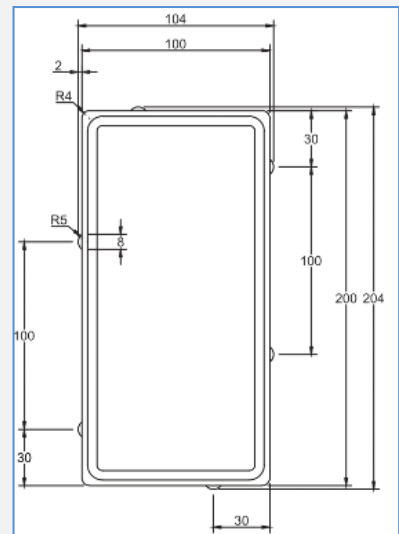

City

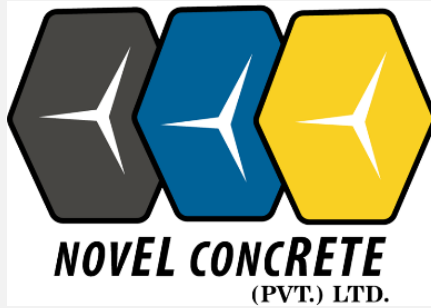

Suit # 306, 3rd Floor Century Tower, Kalma Chowk, Main Boulevard Gulberg, Lahore
Tel: +92-42-35913913

OUR PRODUCTS

SOLID BLOCKS

- Fast Construction
- Strong, durable, and economical
- Saving in plaster
- Saving in Mortar
- High plant controlled quality
- Low maintenance cost
- Water resistant



Available Sizes		
4 x 8 x 12	6 x 8 x 12	8 x 8 12

Applicable Uses

- Exterior and interior walls
- Partition walls
- Boundary walls



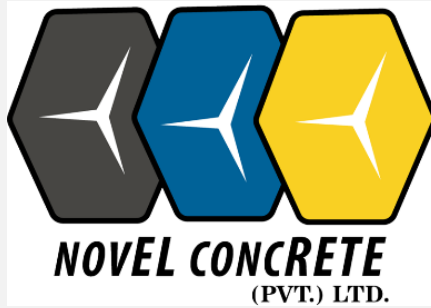

**Suit # 306, 3rd Floor Century Tower, Kalma Chowk, Main Boulevard Gulberg, Lahore
Tel: +92-42-35913913**

OUR PRODUCTS



HOLLOW BLOCKS

- Lightweight
- Quick construction
- Fire resistant
- Better thermal and acoustic insulation

Applicable Uses

- Multi-storey buildings
- Industrial and commercial Buildings
- Exterior and interior walls
- Partition walls

Hollow Blocks VS Clay Bricks

Hollow Blocks	Clay Bricks
	
30% Lower Cost (per sqft)	Higher Cost (per sqft)
80% Time Saving	Time Consuming
High Compressive Strength	Low Compressive Strength
Less Labour Required	More Labour Required
Superior Surface Finish	Poor Surface Finish
Less Pollution & Emissions	More Pollution & Emissions
Less Plastering Required	More Plastering Required
Different Shapes and Sizes	One Standard Shape and Size
Less Seepage & Dampness	More Seepage & Dampness

Available Sizes		
4 x 8 x 16	6 x 8 x 16	8 x 8 16

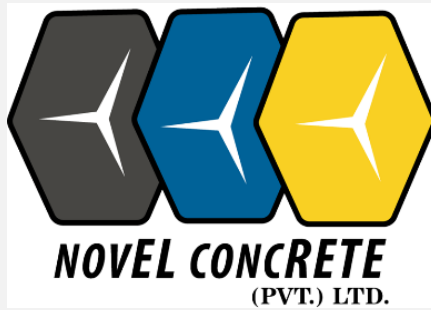

Suit # 306, 3rd Floor Century Tower, Kalma Chowk, Main Boulevard Gulberg, Lahore
Tel: +92-42-35913913

OUR PRODUCTS

CONCRETE BRICK

- Stronger
- Durable
- Water and moisture resistant
- Better surface finish and aesthetics
- No efflorescence and damage to paint, plaster and wallpapers
- Lesser mortar and maintenance required
- Economical and cost effective

Applicable Uses

- Foundations (Seepage control)
- Multi-storey buildings
- Industrial and commercial Buildings
- Exterior and interior walls
- Partition walls

FLY ASH BRICK

- Lighter and stronger
- Durable
- Economical
- Superior surface finish and aesthetics
- Resistant to salt and acid attack
- Green product

Applicable Uses

- Foundations (Seepage control)
- Multi-storey buildings
- Industrial and commercial Buildings
- Exterior and interior walls
- Partition walls

Available Size

- 3.1 x 4.5 x 9.5



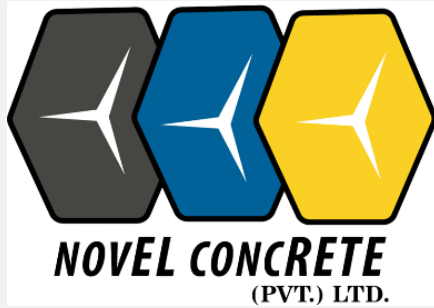

Suit # 306, 3rd Floor Century Tower, Kalma Chowk, Main Boulevard Gulberg, Lahore
Tel: +92-42-35913913

OUR PRODUCTS

KERB STONE



Available Sizes		
6 x 8 x 12	86x 12 x 12	6 x 12 x 18

COBBLE STONE

- High strength
- Skid resistant
- Durable
- Longevity
- Aesthetics



Available Size

- 65mm



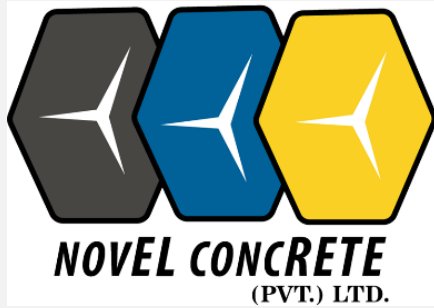

Suit # 306, 3rd Floor Century Tower, Kalma Chowk, Main Boulevard Gulberg, Lahore
Tel: +92-42-35913913

OUR PRODUCTS

PRECAST SLAB AND BOUNDARY WALL

- Fast construction
- Economical and cost effective
- Consistent and superior finish
- Reliability and robustness
- High plant controlled precision
- Reusable

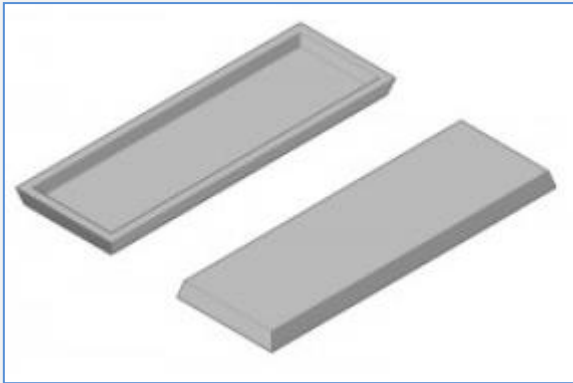

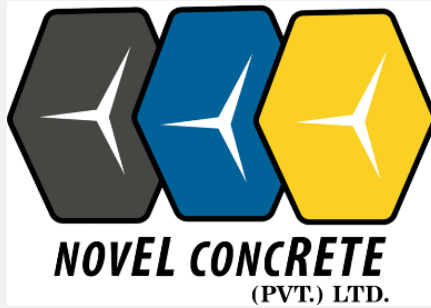

Suit # 306, 3rd Floor Century Tower, Kalma Chowk, Main Boulevard Gulberg, Lahore
Tel: +92-42-35913913

OUR PRODUCTS

OT TILES

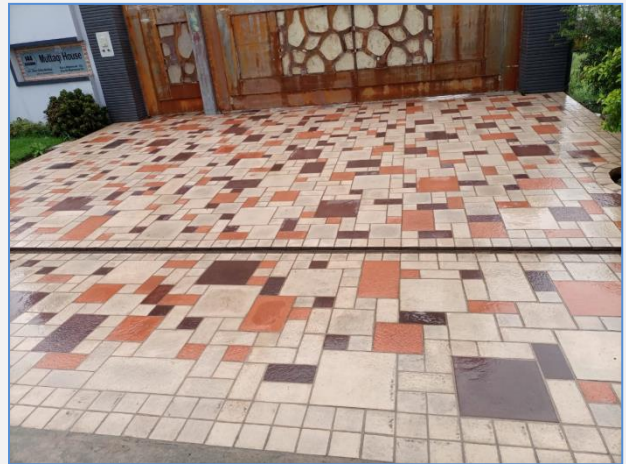

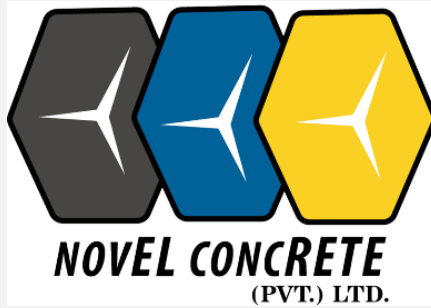

Suit # 306, 3rd Floor Century Tower, Kalma Chowk, Main Boulevard Gulberg, Lahore
Tel: +92-42-35913913

OUR MAJOR CLIENTS

